



Exercise: Charge Amplifier

Prof. Dr. P. Fischer

Lehrstuhl für Schaltungstechnik und Simulation
Uni Heidelberg



Motivation

- Many sensors deliver charges (e.g. photo diodes)
- We want to amplify such (small) charge signals
 - Our goal will be to see, e.g. 1000 electrons. Can we see 100?

- A critical question will be the noise in the circuit
- We will reduce the noise by
 - Dimensioning the transistors in the amplifier
 - More current
 - Filtering

- We will start with an idealized circuit and refine it step by step
- We will have to consider the capacitance of the ‘detector’ at the input



Ideal Charge Amplifier

- An ideal charge amplifier consists of an inverting amplifier with large gain A_0 and a 'small' feedback capacitor C_f .

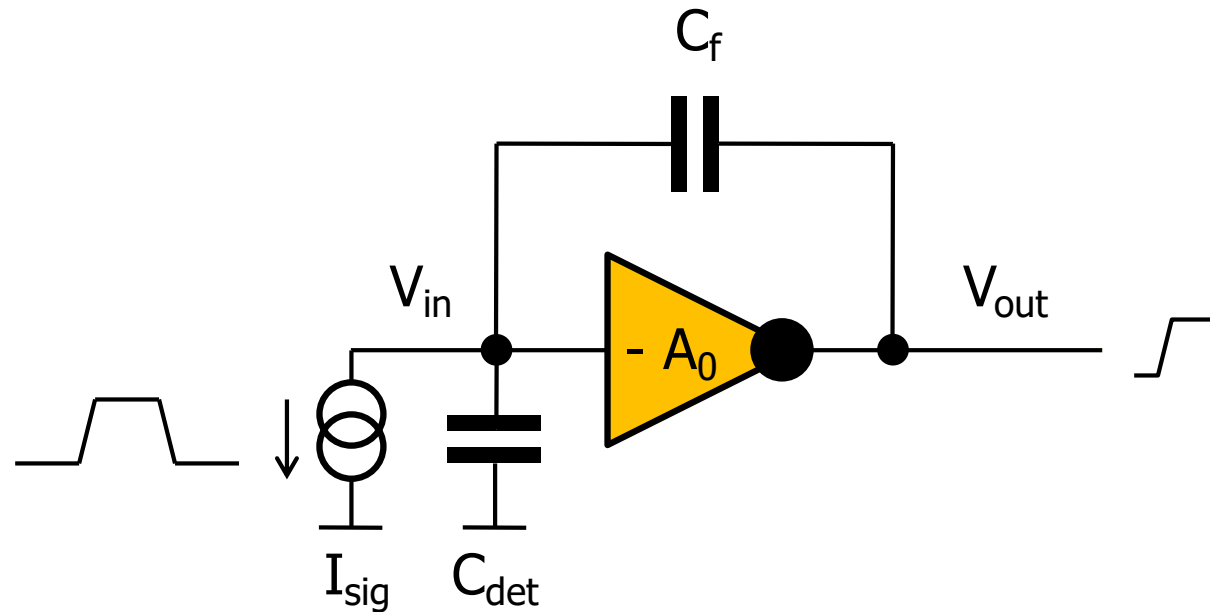

- The input charge is delivered by a trapezoidal current pulse
- For the start, we neglect the input capacitance C_{det} .



Basic Operation

- The current shall have rise/fall times 1ns and a plateau of 5ns.
- What plateau current do you need to deliver $Q_{in} = 1 \text{ fC}$?
- Use a vcvs with as amplifier
 - Ground the positive input
 - Use a gain of 100 to start with
- Start with $C_f = 100 \text{ fF}$. Make sure it is discharged at $t=0$.
- Simulate the circuit. What is the output voltage after Q_{in} ?
- Calculate the amplitude of the output signal (after all charge has arrived) as a function of Q_{in} , A_0 and C_f .
 - Hint: When $C_{det} = 0$, all input charge must flow to C_f . Input and output voltage are related by A_0 .
 - When later $C_{det} > 0$, some charge is left on C_{in} , depending on V_{in} .



Discharging Cf

- Inject two consecutive charge packets at $t=10\text{ns}$ and $t=100\text{ns}$
- The output does not 'come back to 0'. This is not good.
- Add a discharging *resistor* R_f in parallel to C_f .
- What value do you need to discharge in roughly $1\mu\text{s}$?
Simulate and calculate.
- The resistor effectively removes the charge from the input node.
- Tricky: Can you use a v_{ccs} to achieve the same effect?



Adding a Source Follower

- Add a source follower (MOS + current source) to the output
- Connect R_f after the SF.
 - What changes? Why?
- Connect C_f after the source follower
 - What changes? Why?



Adding a Detector

- Now add a detector capacitance of, say, 10 pF.
- How does the output change? Why?
- What can you do to get more voltage?
- Try this out!
- Derive a formula of the signal height as function of Q_{in} , A_0 , C_f and C_{det} .
- Try out some extreme cases and compare simulation result and calculation.



A real Amplifier

- Replace the idealized amplifier (i.e. the vcvs) by an NMOS gain stage with an ideal current source load.
 - What is a good operation point?
 - What is the best operation point?

- Simulate the gain
 - What is a good operation point?
 - What is the best operation point?

- Simulate the charge amplifier output (with Cdet).
 - Do you find what you expect?

- Increase the current more and more.
 - What happens?
 - Why?