



Some BASICS

Voltage, Current, Components and AC behavior,
Bode Plots, Transfer Functions, Thévenin Equivalent,
High-pass and Low-pass filters,...



Prefixes for Units

- For writing down small or large quantities, exponents can be used: $1.5 \times 10^6 \Omega$, $3 \times 10^{-9} A$

- To simplify, **prefixes** in steps of 1000 are used:

• T	Tera	$\times 10^{12}$
• G	Giga	$\times 10^9$
• M	Mega	$\times 10^6$
• k	Kilo	$\times 10^3$
•	1	$\times 10^0$
• m	Milli	$\times 10^{-3}$
• μ (or u)	Mikro	$\times 10^{-6}$
• n	Nano	$\times 10^{-9}$
• p	Piko	$\times 10^{-12}$
• f	Femto	$\times 10^{-15}$
• a	Atto	$\times 10^{-18}$

This range is *really* used in chip design

- Try to learn: ‘Piko \times Kilo = Nano, Milli \times Mega = Kilo,...’



VOLTAGE, CURRENT, KIRCHHOFF'S LAWS



Voltage

- Voltage is the *difference* in electrical potentials, i.e. the energy required to move a unit charge in an electric field
 - This is only well defined in static fields where $\text{rot } E = 0$
- Unit: Volt (V)

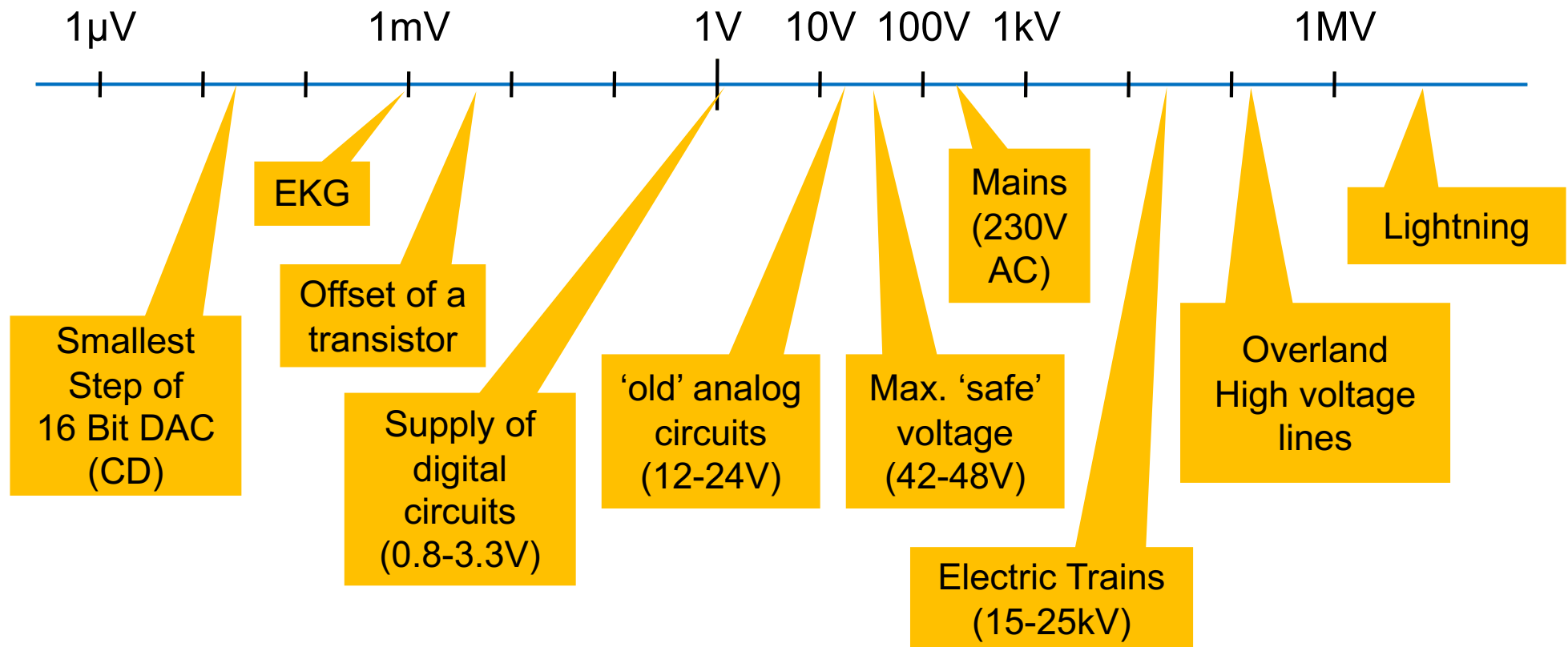



Ground

- Voltages are really potential **differences**
- To simplify life, we define a **reference potential** to which voltages are referred. We call it '**ground**'
 - i.e. when we say 'net A has 3V', we mean $V_A - V_{\text{GND}} = 3\text{V}$
 - Ground is at 0V by definition

- Common ground symbol are: 

- (Later we may use several grounds, all at 0V, but separated, for digital and analogue circuit parts)



Current

- Electric current is the flow (or change) of electric charge
- $i = dQ / dt$
- Unit: Ampere (A)

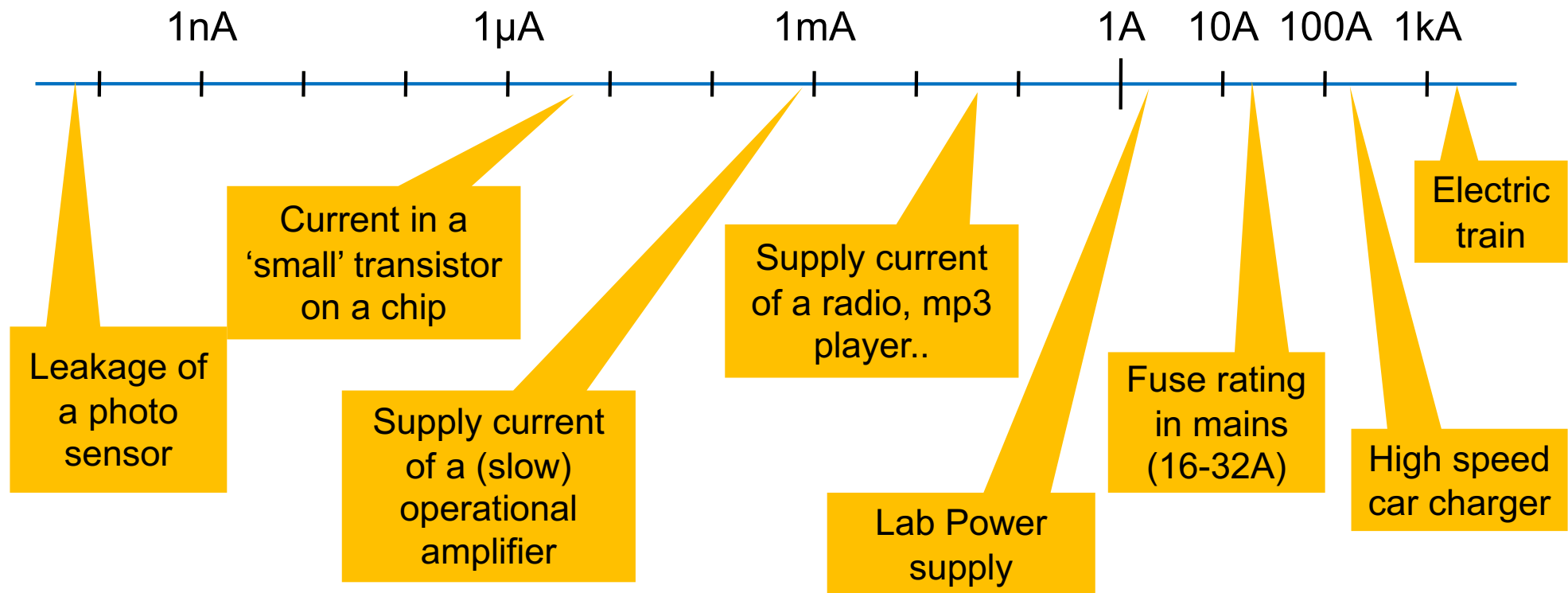



Kirchhoff's Laws

1. The sum of currents at any node is zero:

$$\sum_{k=1}^n I_k = 0$$

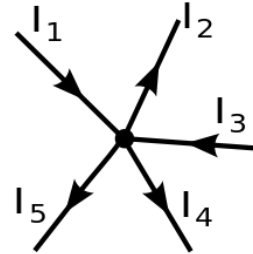

- Follows from charge conservation

2. The sum of voltages in any closed loop is zero:

$$\sum_{k=1}^n U_k = 0$$

The sign of the U_k is fixed by a consistent ordering of the nodes in the loop.

Example:

$$U_1 = U_B - U_A, U_2 = U_C - U_B, \dots$$

$$U_1 + U_2 + U_3 + U_4 = 0$$

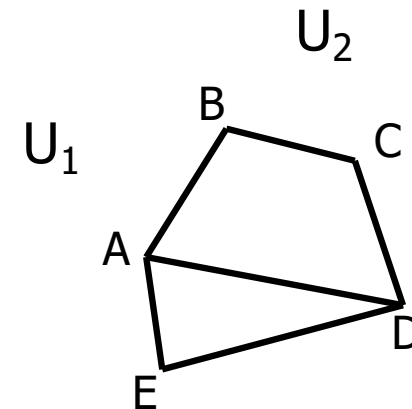

- Follows from energy conservation



RESISTORS



Resistors

- A resistor is a 2 terminal device
- When voltage is applied, a current flows
- **Ideally**, current is **proportional** to the voltage (Ohm's 'law'):

$I = U \times G$ G is the **conductivity** (Leitwert) in Siemens [S]
or

$I = U / R$ R is the **resistivity** (Widerstand) in Ohm [Ω]

- G and R describe the same thing. $G = 1/R$, $R = 1/G$

- Symbols:

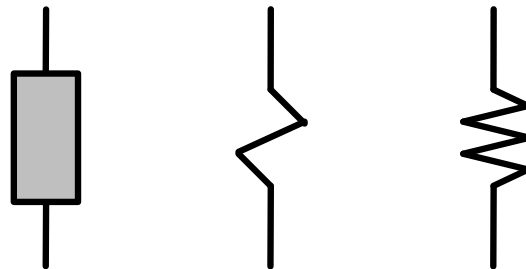

- Note: **Ohm's 'law' is no law**. Not all materials are 'ohmic'



Parallel Connection of Resistors

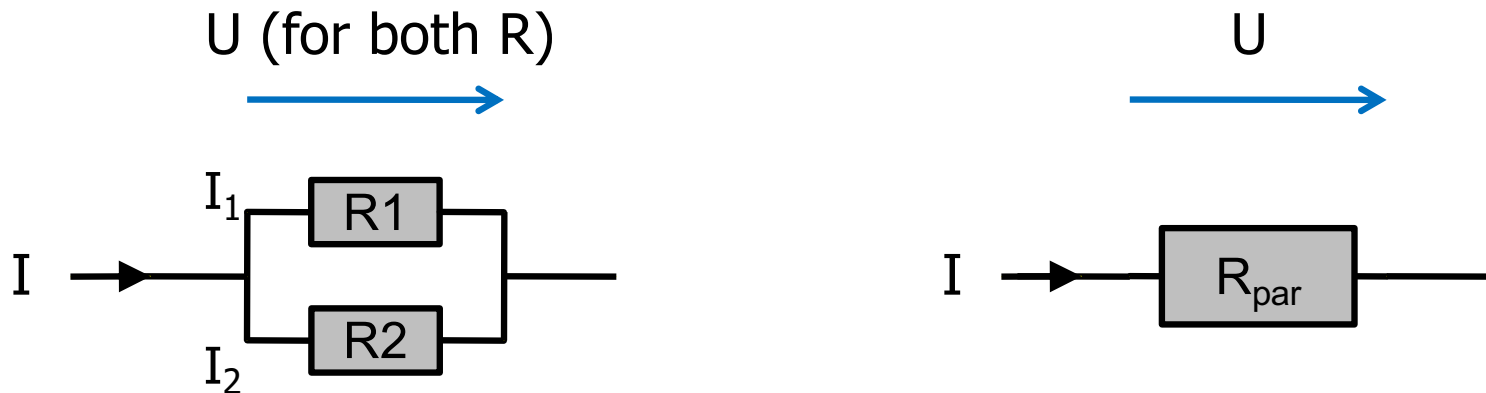

$$I = I_1 + I_2 = G_1 \times U + G_2 \times U = (G_1 + G_2) \times U$$

$$I = G_{\text{par}} \times U$$

$$G_{\text{par}} = G_1 + G_2 \quad \leftrightarrow \quad 1/R_{\text{par}} = 1/R_1 + 1/R_2$$



Series Connection of Resistors

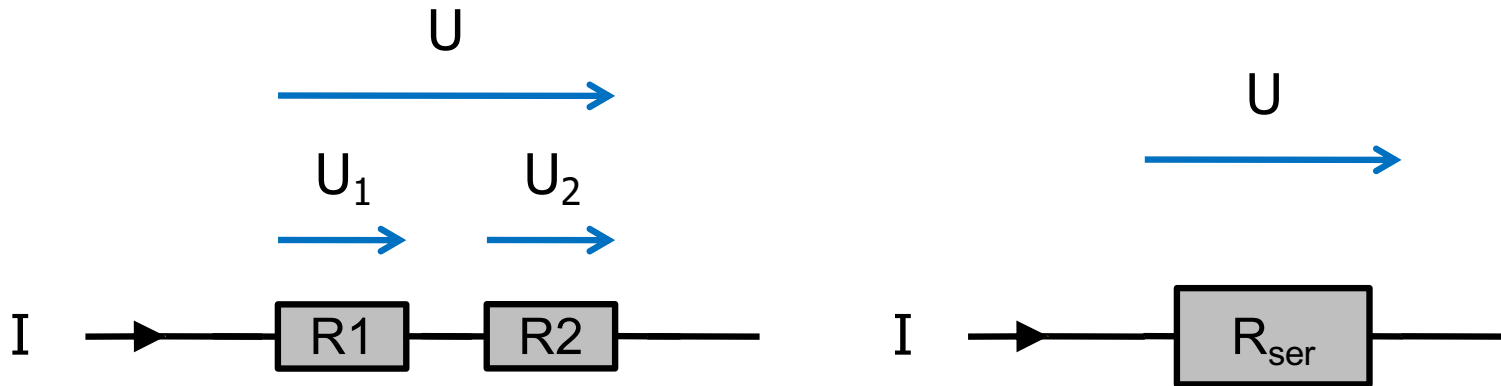

$$U = U_1 + U_2 = I \times R_1 + I \times R_2 = I \times (R_1 + R_2)$$

$$U = I \times R_{ser}$$

$$R_{ser} = R_1 + R_2 \quad \leftrightarrow \quad 1/G_{ser} = 1/G_1 + 1/G_2$$



The Voltage Divider (*without* load current!)

- An **omnipresent** topology is the voltage divider:

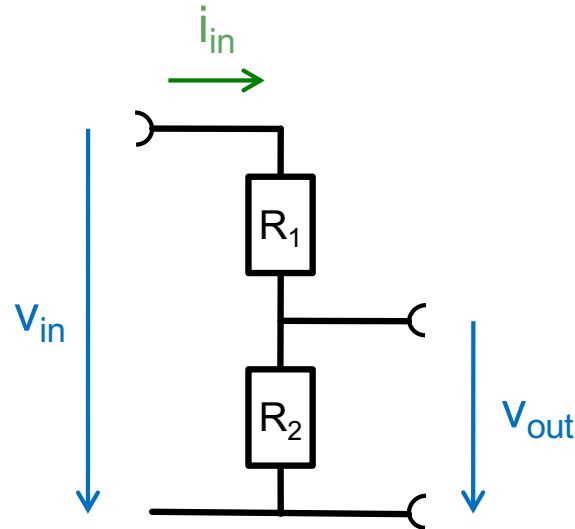

Very Important!

- The input current $i_{in} = v_{in} / (R_1 + R_2)$
 - This current flows through R_1 and R_2 , i.e. $i_{in} = i_{R1} = i_{R2}$
 - On R_2 , it develops a voltage $v_{out} = i_{R2} R_2 = i_{in} R_2 = v_{in} R_2 / (R_1 + R_2)$
- Overall: $v_{out} / v_{in} = R_2 / (R_1 + R_2)$
 - Remember: The 'gain' is the *value of the resistor where we measure* divided by the *total resistance*



CAPACITORS



Capacitors: Water Analogy

- A capacitor is a container for charge. Analogy using water:

Current \Leftrightarrow Water flow ($\text{m}^3 / \text{second}$ or so)

Voltage \Leftrightarrow Water level (m)

Capacitance \Leftrightarrow Area of a container (m^2)

$V = T I / C \Leftrightarrow$ level = time x flow / area

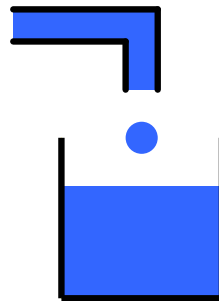

- Water flowing in the container leads to rising water level.

- Higher flow (current) \rightarrow faster increase of (voltage) level
- Larger container (cap) \rightarrow slower (voltage) increase

- With this model, we can also visualize nonlinear caps:

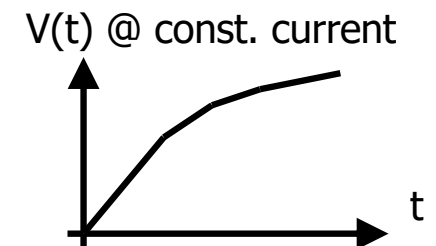



Capacitors: Store Electric Charge

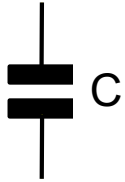

- **Prototype: parallel plate capacitor**

- **Charge Q** on plates generates a *proportional* electric field **E** (Gauss' law)
- The field between plates leads to a *proportional voltage V*
- → **Q** and **V** are *proportional*

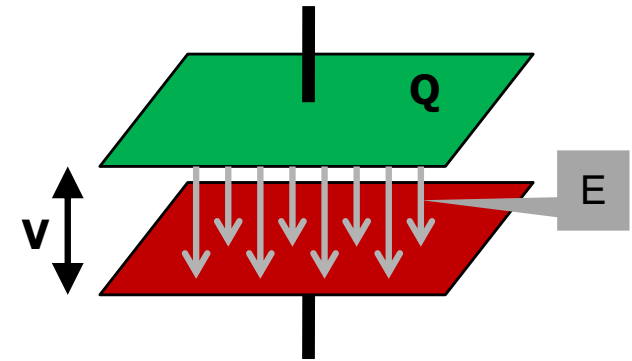

- **Q = C × V**: capacitance is factor between charge and voltage
- A **large** capacitor can store a **lot** of charge at **low** voltage
- The voltage on a capacitor is given by the current integral:

$$V = \frac{Q}{C} = \frac{1}{C} \int I(t) dt \quad \Leftrightarrow \quad I(t) = C \frac{dV}{dt}$$

- The stored energy (denoted here also with E) is:

$$dE(Q) = V(Q)dQ \Rightarrow E = \int_0^Q V(Q')dQ' = \int_0^Q \frac{Q'}{C}dQ' = \frac{Q^2}{2C} = \frac{1}{2}CV^2$$

Energy required to add a charge dQ to a capacitor which already contains the charge Q



Charging a Capacitor (important!)

Very Important!

- At constant current I : **linear ramp**:

$$I(t) = I_0 = \text{const}$$

$$\Delta Q(t) = \int_0^t I(t') dt' = \int_0^t I_0 dt = I_0 \times t$$

$$\Delta U(t) = \frac{\Delta Q(t)}{C} = \frac{I_0}{C} \times t$$

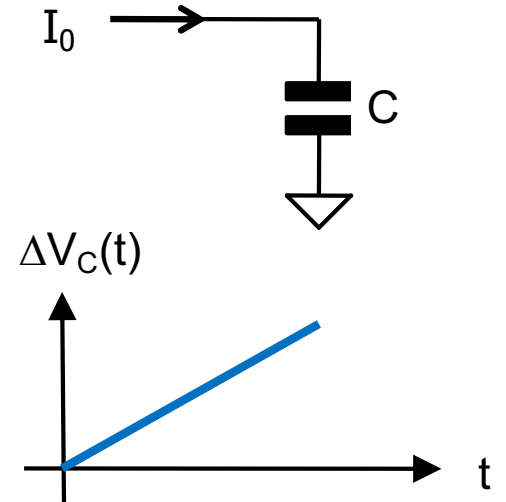

- Through resistor R : **exponential settling**:

$$I(t) = \frac{U_0 - U(t)}{R}$$

$$\frac{dU(t)}{dt} = \frac{I(t)}{C} = \frac{U_0 - U(t)}{RC}$$

$$\text{Solution : } U(t) = U_0 - U_0 e^{-\frac{t}{RC}}$$

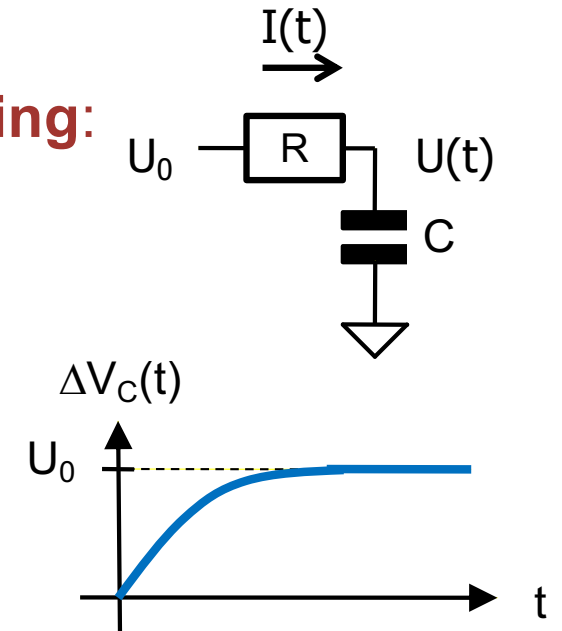



Parallel and Series Connection of Capacitors

- For derivation, see exercise...

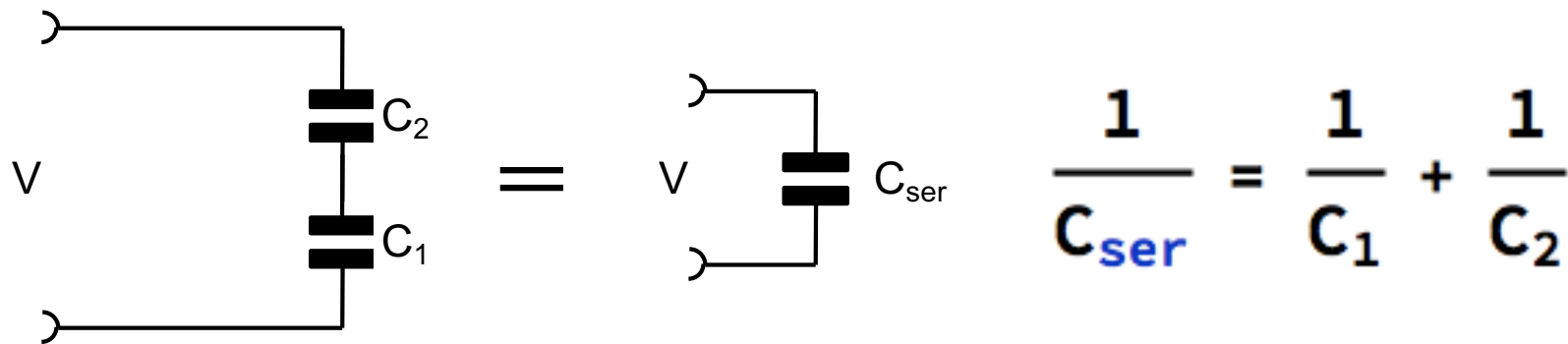
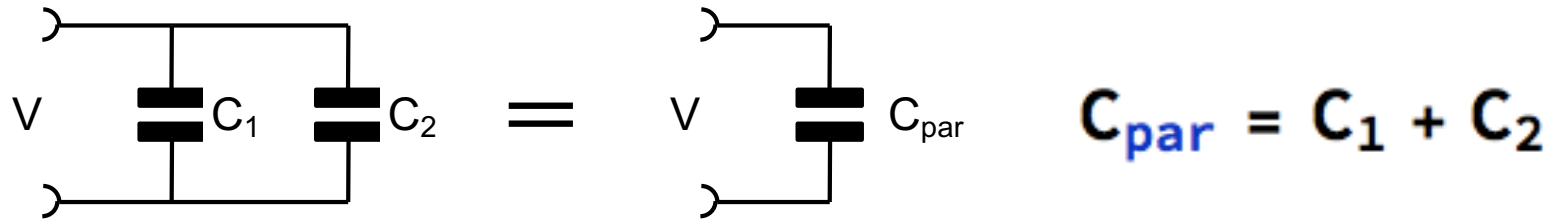



VOLTAGE & CURRENT SOURCES



Voltage Sources

- A voltage source has 2 terminals:

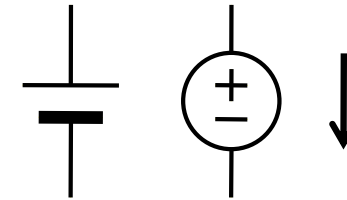

- An **ideal** voltage source maintains the voltage for **any** output current ('1000 A')
- The voltage of a **real** source drops with **load current**.
- This is modeled by a **series** resistor (internal resistor, source resistor):

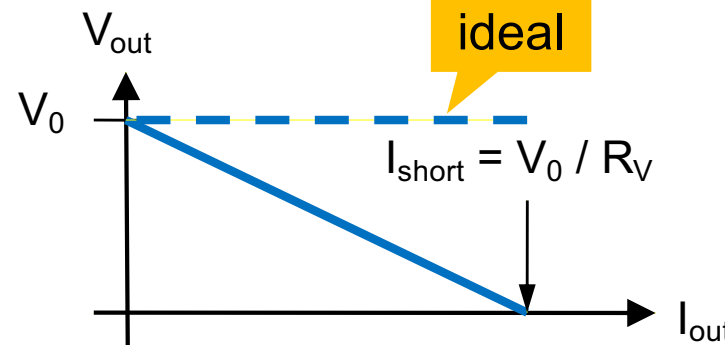
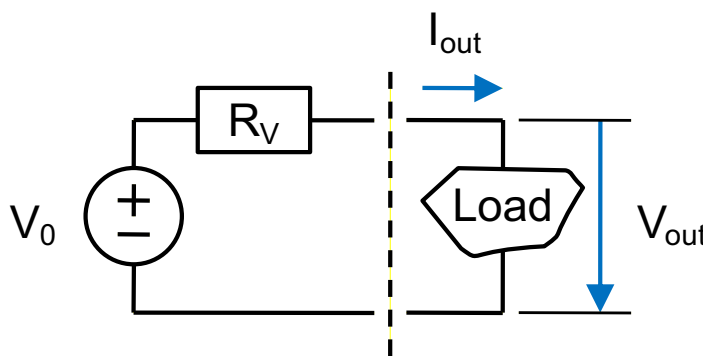

- The **open voltage** is V_0 ($I_{out}=0 \rightarrow$ voltage drop over R_V is 0)
- The **short circuit current** is $I_{short} = V_0 / R_V$
- Note: '**Good**' voltage sources have **low** $R_V \rightarrow 0$



Current Sources

- A current source has 2 terminals:

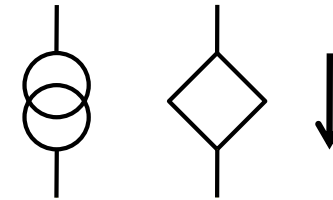

- An **ideal** current source maintains the current for **any** output voltage
- The current of a **real** source drops with **load voltage**.
- This is modeled by a **parallel** resistor (internal resistor, source resistor):

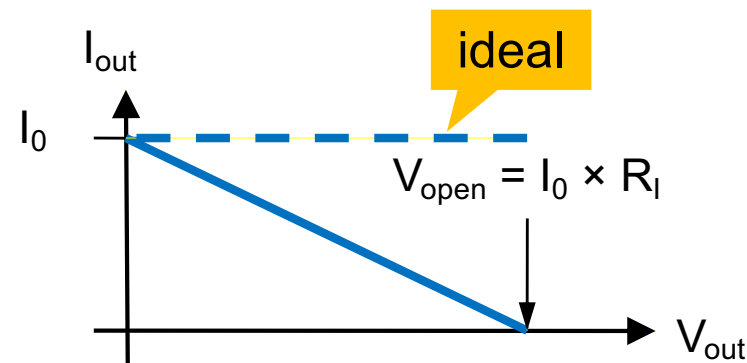
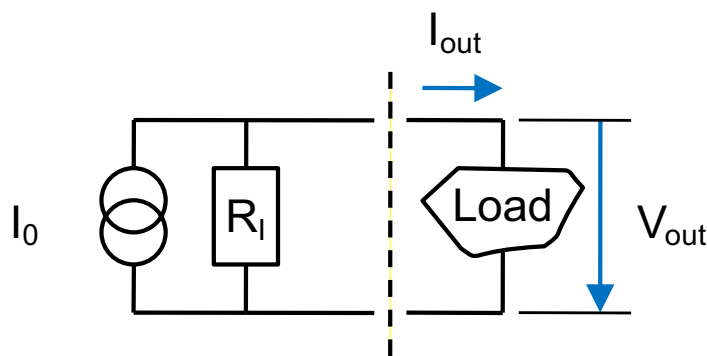

- The **short circuit current** is I_0 (no voltage at $R_i \rightarrow$ no current)
- At a voltage of $I_0 \times R_i$ no more current flows (all flows in R_i)
- Note: '**Good**' current sources have **high** $R_i \rightarrow \infty$



Equivalence of U- and I-Source

- Flip the diagram of the I-source and compare:

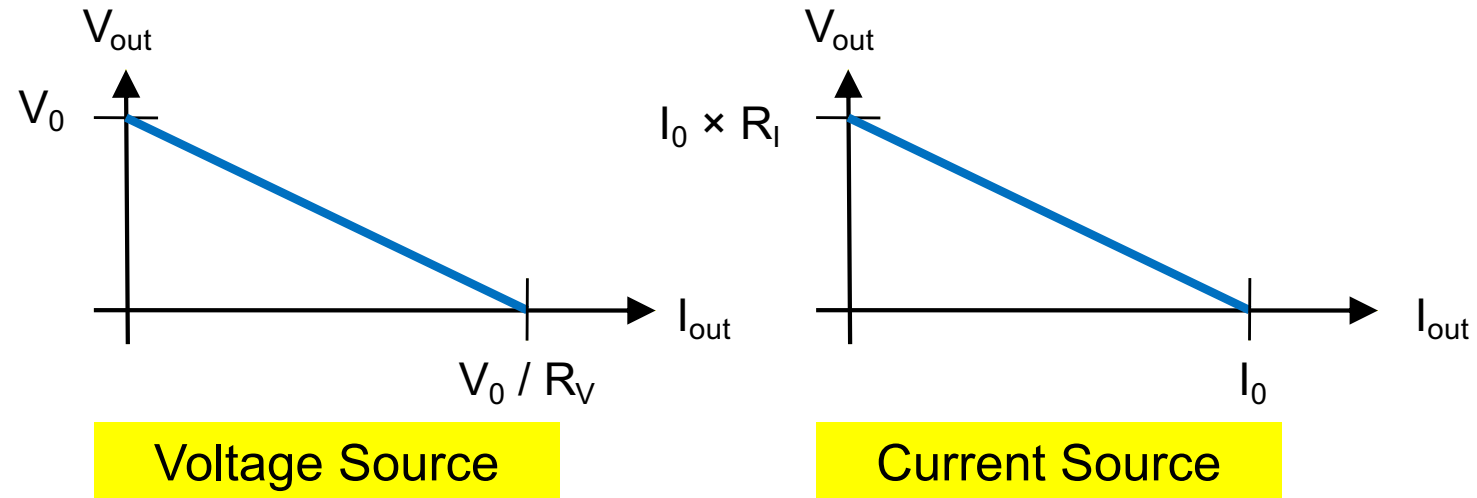

- Same shape! Therefore:
- For voltage source with V_0 and R_V , a current source with $I_0 = V_0 / R_V$ and $R_I = V_0 / I_0 = R_V$ behaves the same!

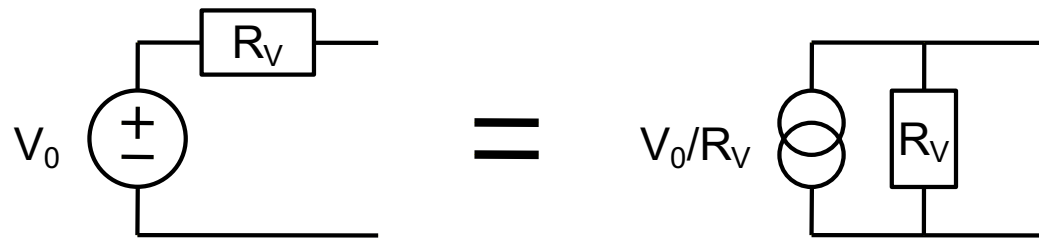



Thévenin's Theorem

Any combination of U-sources, I-sources and resistors behaves like a (ideal) voltage source with an internal resistor

- This is fairly obvious from the previous page and the linearity of the resistor properties
- Obviously, a current source with internal resistor can also be used
- Example:

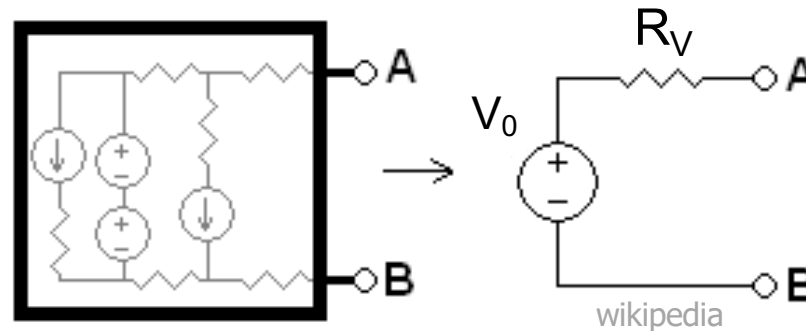

- To find V_0 : calculate the open voltage
- To find R_V : find the short circuit current. Then $R_V = V_0 / I_{\text{short}}$



A More Complicated Example

- What is the Thévenin equivalent of this circuit ?

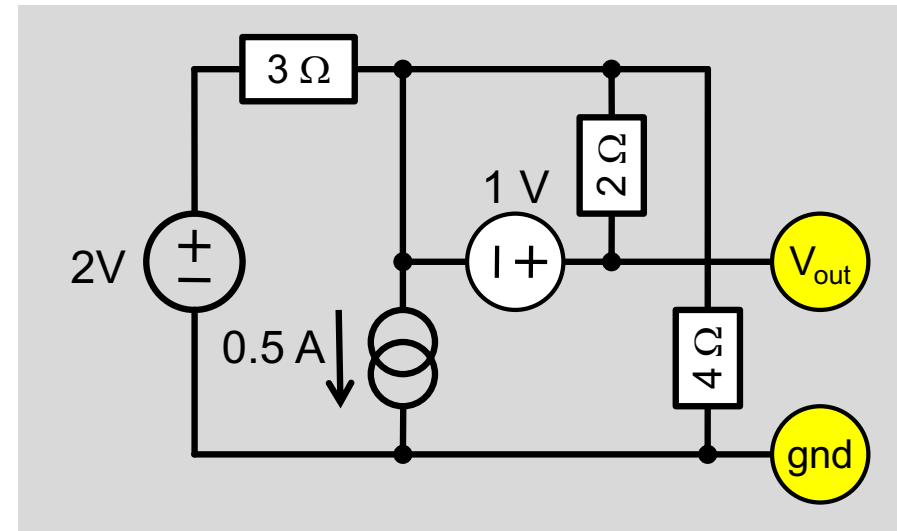

- Before we start
 - Label nodes
 - Re-draw schematics for better understanding:

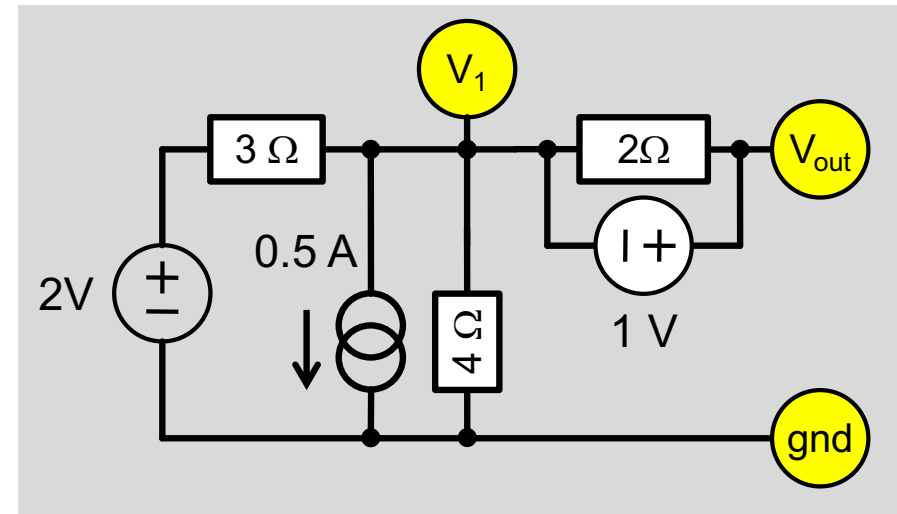



A More Complicated Example

- Open circuit:

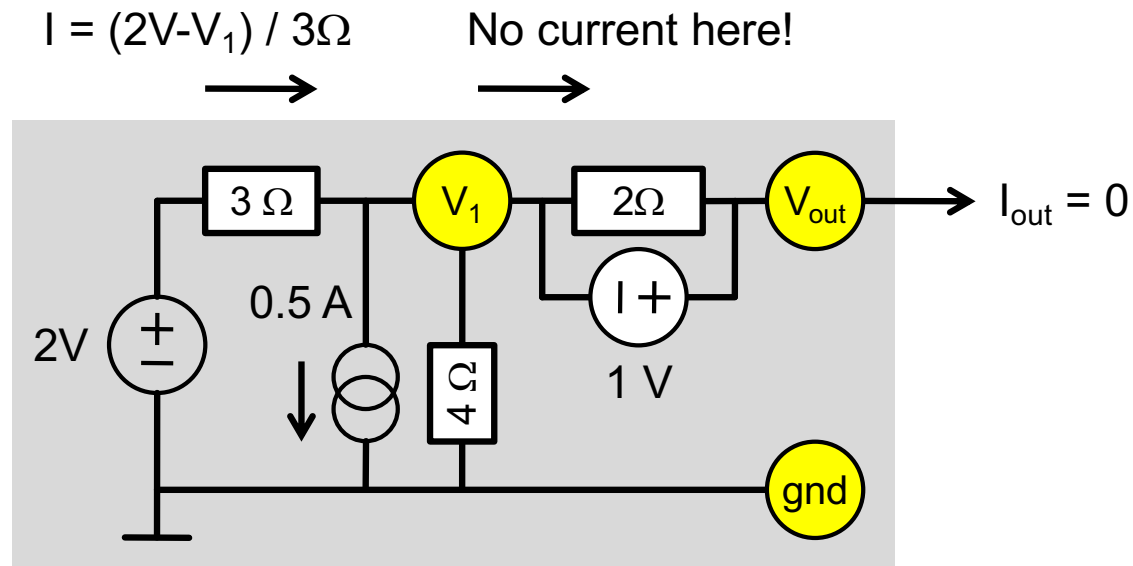

- Current sum at node V_1 :

- $(2V - V_1) / 3\Omega = 0.5\text{ A} + V_1 / 4\Omega \rightarrow V_1 = 0.285.. \text{ V}$

- $V_{\text{out}} (I_{\text{out}}=0) = V_1 + 1V = 1.285.. \text{ V} = V_{0,\text{eq}}$



A More Complicated Example

- Short circuit ($V_{out}=0$):

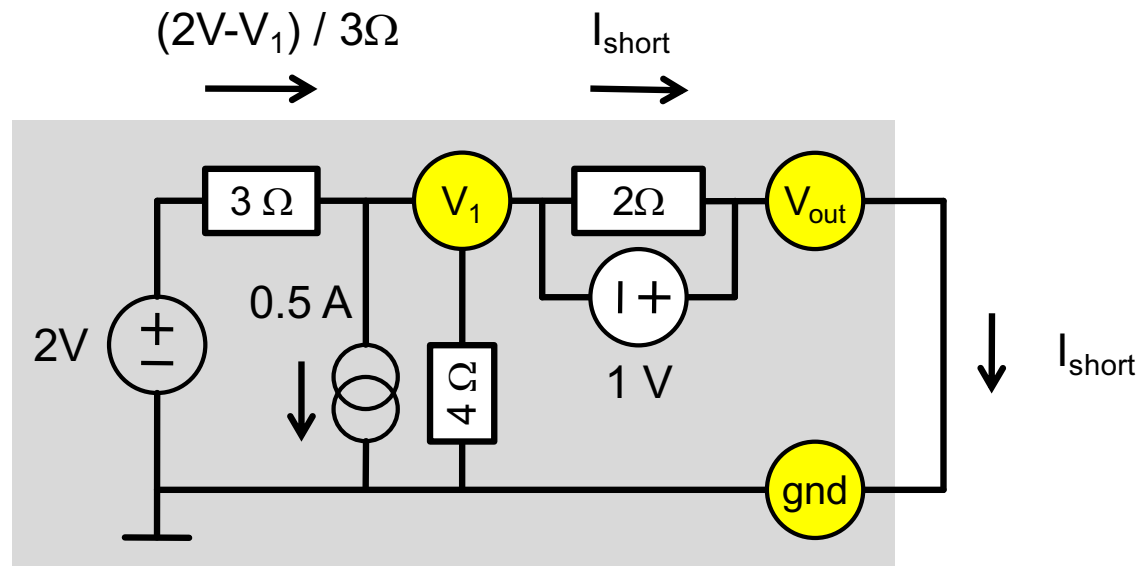

- Here we have $V_{out} = 0V$ and therefore $V_1 = -1V$

- Again current sum at node V_1 :

$$\bullet (2V - V_1) / 3 \Omega = 0.5 A + V_1 / 4 \Omega + I_{short} \quad \begin{matrix} V_1 = -1V \\ \rightarrow \end{matrix} \quad I_{short} = 0.75 A$$

- $R_V = V_{0,eq} / I_{short} = 1.285.. V / 0.75 A = 1.71 \Omega$



A More Complicated Example - Simulation

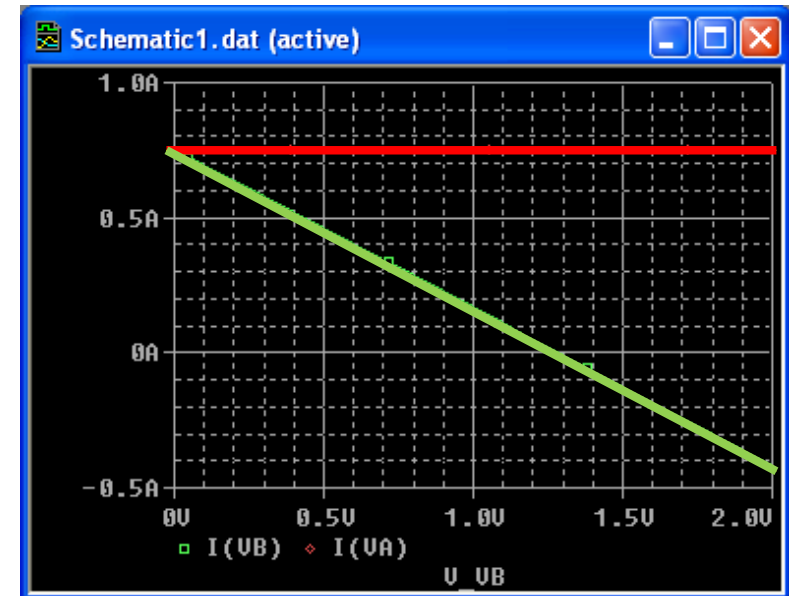
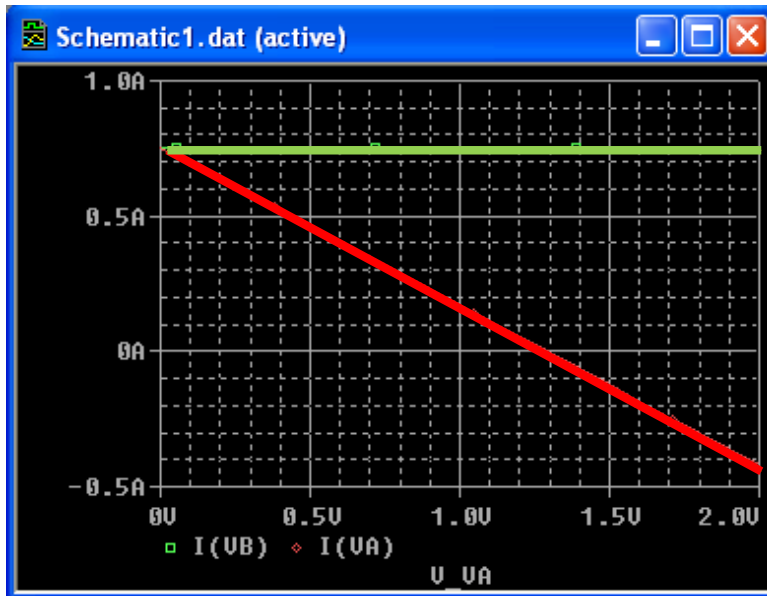
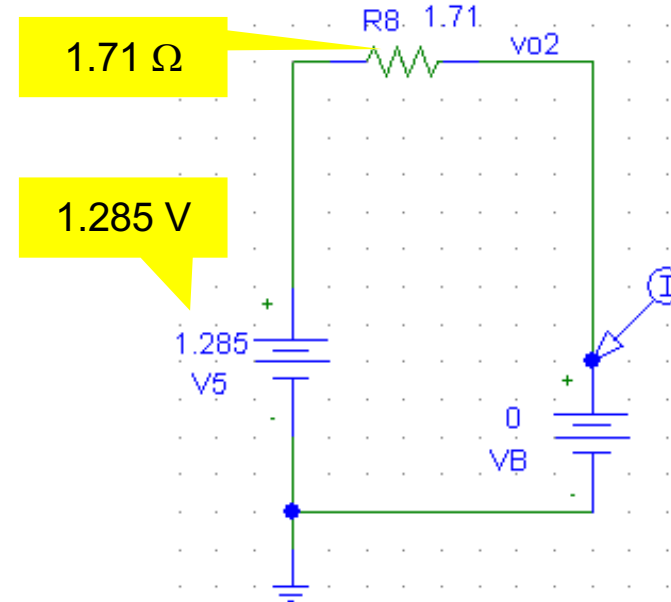
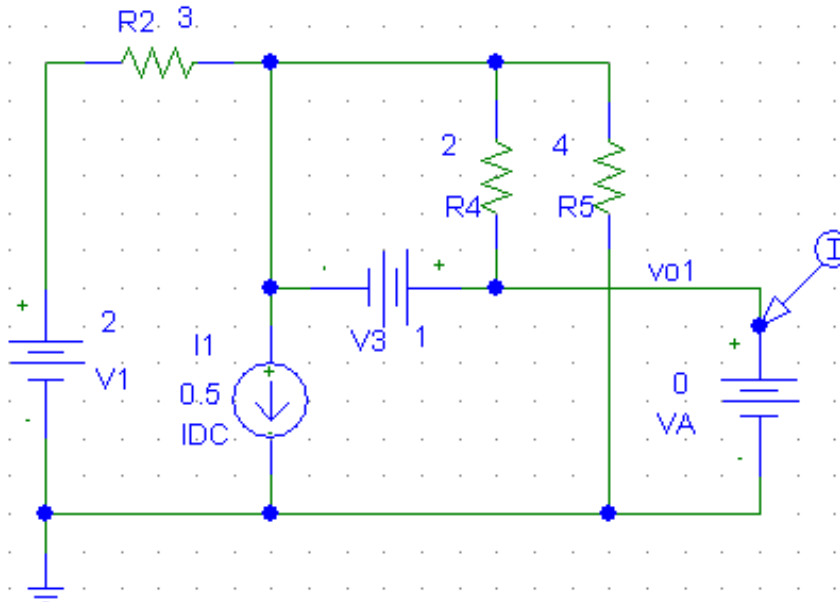



Thévenin Equivalent of a Voltage Divider

- Consider a voltage divider with two equal resistors:

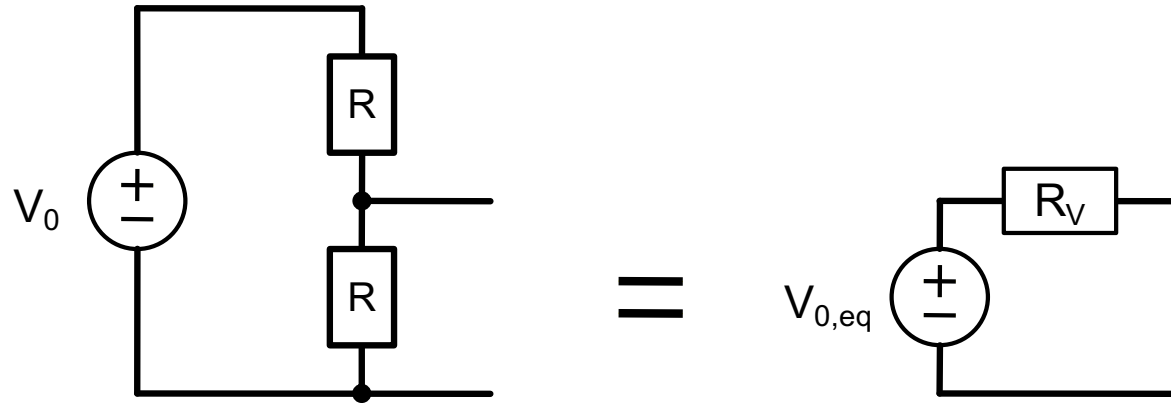

Very Important!

- $V_{0,eq} = V_0 / 2$ ($I = V_0 / (2R)$, $V_{0,eq} = R \times I$)
- $I_{short} = V_0 / R \rightarrow R_V = V_{0,eq} / I_{short} = R / 2$

- In the general case R_V is the parallel connection of R_1 and R_2 . Remember that!



DRAWING SCHEMATICS



Drawing Schematics: Some Rules

- **Positive** voltages are at the **top**, negative at the bottom
- **Input** signals are at the **left**, **outputs** at the **right**
- Connected **crossings** are marked with a ● :
 - should be avoided
- T-connections do not need a ● :
 - but they **can have** one (I often prefer to put one)...

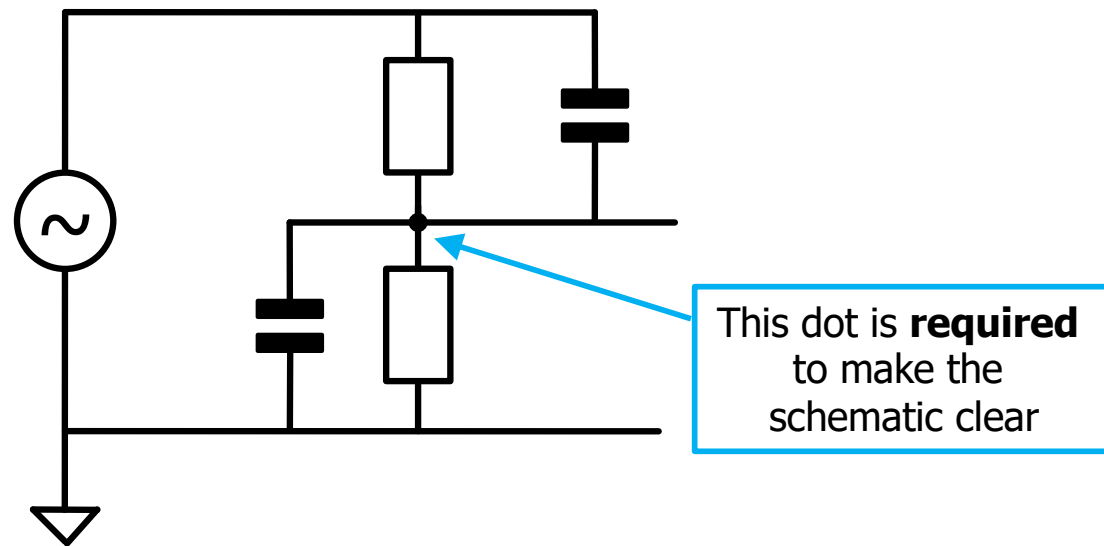
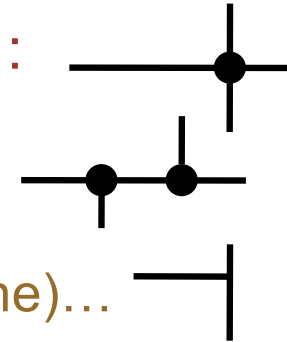



Signal Flow

- Ground should be at the bottom
- Positive voltages at the top
- Signal from should flow **from left to right**
 - Inputs left, outputs right

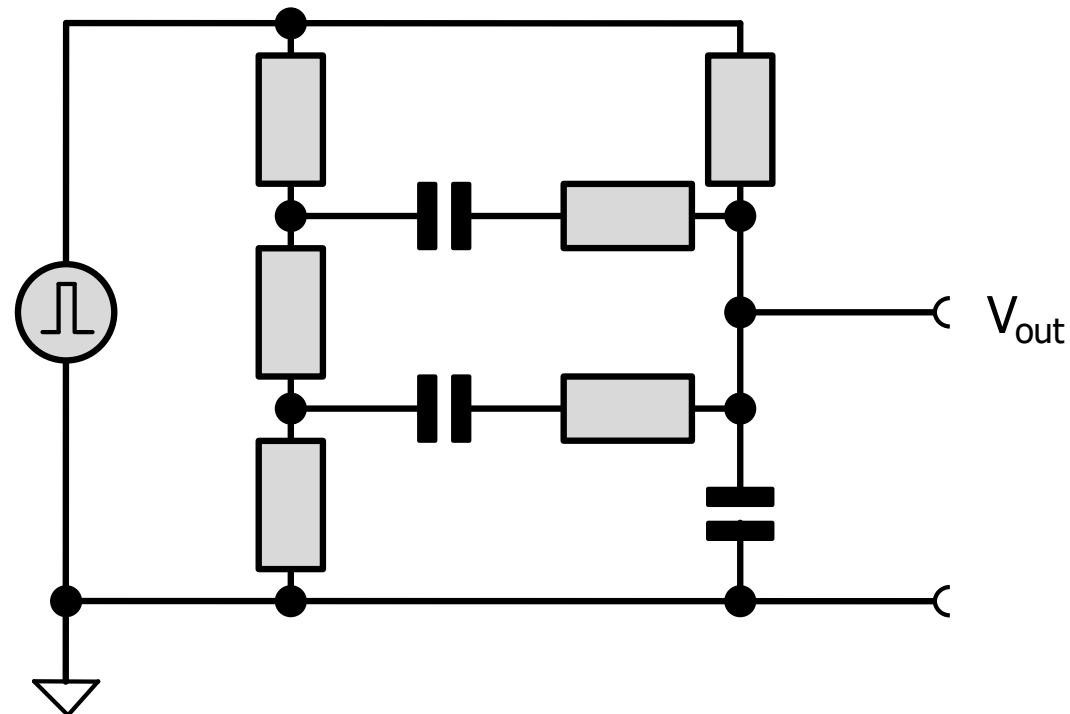



A not so nice schematic

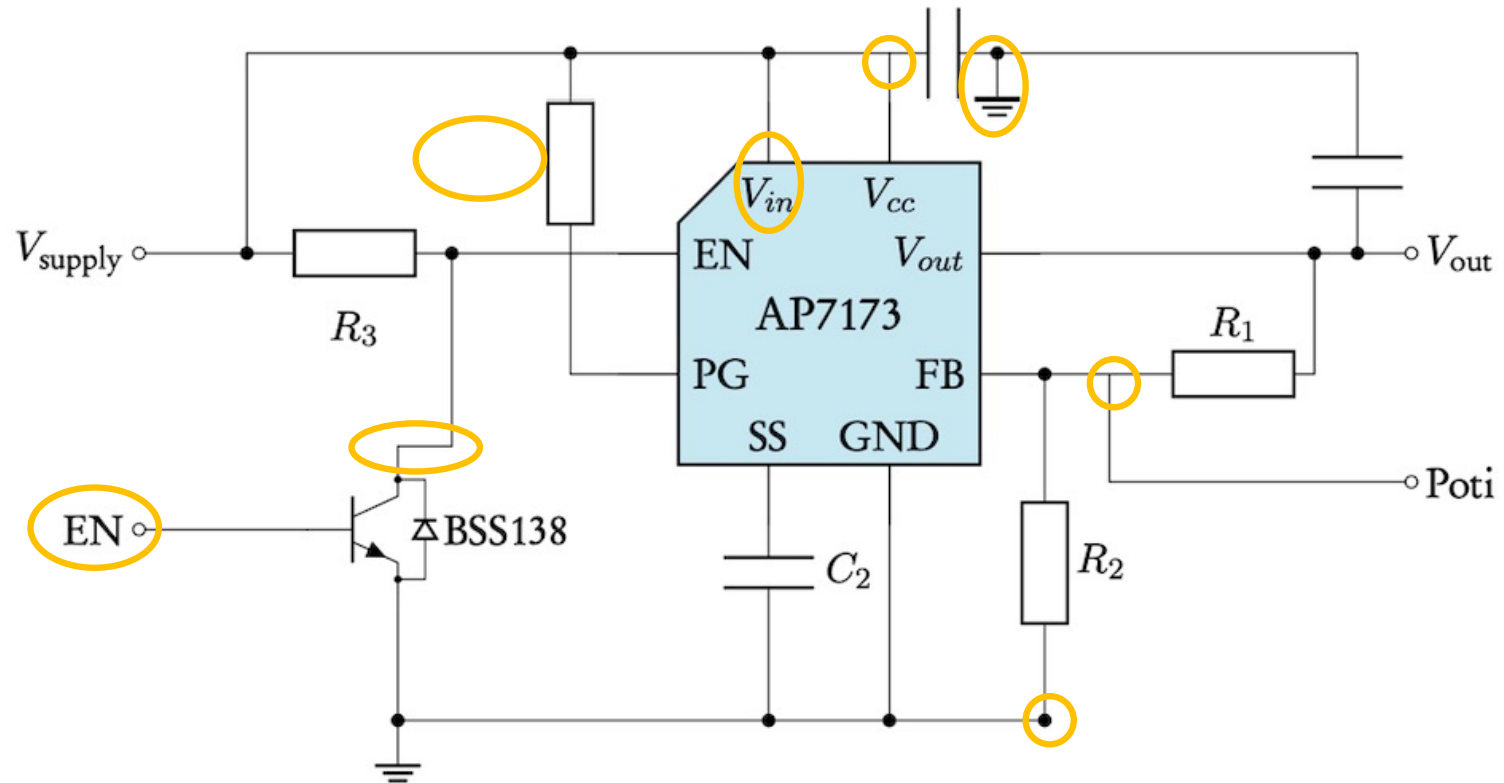

- This is Voltage regulator.
 - Ground should be at the bottom.
 - The cap at the top is an input decoupling cap
 - The output voltage should be in one row
 - ...